

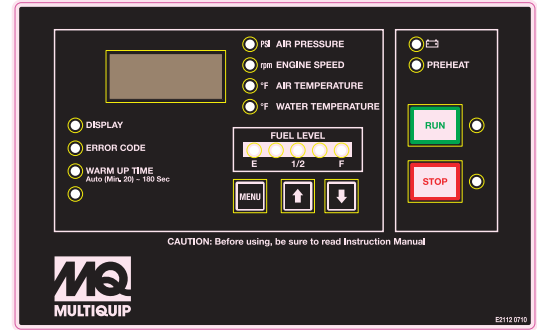

# DIS185SSI4F

## MQ POWER Air Compressor

CFM Rating — 185

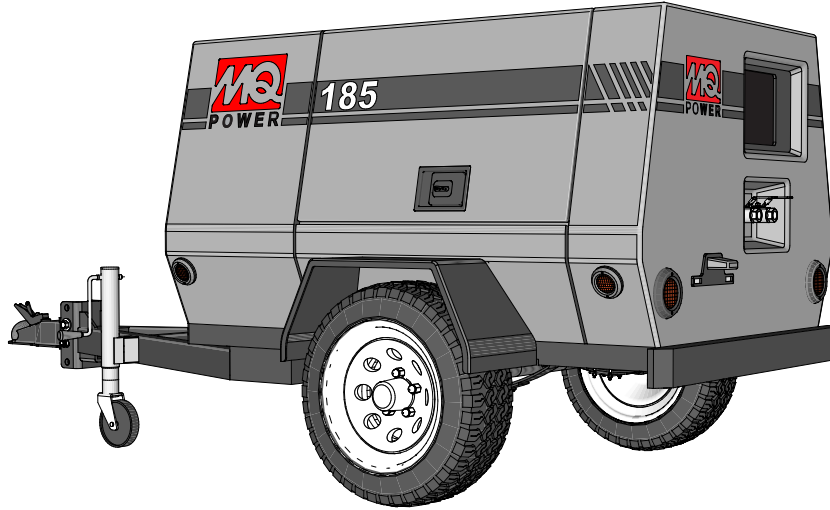

DIGITAL CONTROLLER

### STANDARD FEATURES

- Heavy duty, 4-cycle, direct injection, turbocharged diesel engine provides maximum reliability.
- EPA emissions certified - Tier 4 final emissions compliant.
- Sound attenuated, weather resistant, steel housing provides operation at 69 dB(A) at 23 feet. Fully lockable enclosure allows safe unattended operation.
- Large side doors to provide access to engine and compressor.
- Lockable internal tool box for storing tools and hoses.
- Bolt on steel fender.
- D.O.T approved tail lamps, stop lamps, turn signal lamps and side marker lamps.
- Tongue mounted swivel jack with caster.
- 4-hole channel allows 3-position, adjustable coupler height; 4-inches O/A.
- Single-axle design with leaf spring suspension.
- E-coat and powder coat paint provide durability and weather protection.
- Digital Controller provides readouts with LED status indicator:
  - Compressor Temperature
  - Engine Temperature
  - Engine Speed
  - Fuel Level
  - Complete Engine Diagnostic Tool

### SPECIFICATIONS

Air Compressor Specifications	
Type	Rotary Screw
Rated Delivery	185 CFM (5.2 m <sup>3</sup> min)
Rated Operating Pressure	100 psi (6.9 Bar)
Oil Capacity	4.5 gallons (17 liters)
Air Service Connections	Two 3/4" MNPT
Type Cooling System	Oil to Air
Minimum Operation Pressure	70 psi (4.9 Bar)
Maximum Operation Pressure	125 psi (8.6 Bar)
Air Cleaner (Air Compressor)	2-Stage Filter
Sound Level dB(A) Full Load at 23 Feet	69

Engine Specifications	
Make / Model	Isuzu / 4LE2T
Emissions	Tier 4 Final Certified
Starting System	Electric
Design	4-cycle, Water Cooled, Direct Injection, Turbocharged
Displacement	133.0 in <sup>3</sup> (2179 cc)
Gross Engine Power Output	49 HP
Engine Speed (RPM)	2400
Idle Speed (RPM)	1350
Oil Capacity	2.7 gallons (10.2 Liters)
Coolant Capacity	1.8 gallons (6.8 Liters)
Air Cleaner (Engine)	2-Stage Filter
Battery	12V, Group 27, CCA 800



# DIS185SSI4F

## MQ POWER Air Compressor

### SPECIFICATIONS (CONTINUED)

#### Fuel System

Recommend Fuel	ASTM-D975-No. 1 & No. 2-D*	
Fuel Tank Capacity	24 gallons (90 liters)	
Fuel Consumption	gph	lph
At full load	2.52	9.5
At 1/2 load	1.36	5.1

\* Ultra low Sulfur Diesel Fuel

#### Trailer Specifications

Gross Axle Weight Rating (GAWR)	3500 lbs. (1588 kg)
Tire Size	ST205/75D14 LR-C
Tow Bar Design	Bolt on "A" Frame
Jack Stand type	Caster

#### Weight

Dry Weight	2112 lbs. (960 kg)
Wet Weight	2343 lbs. (1065 kg)

### Coupler Options

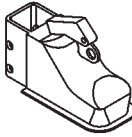
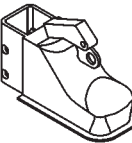
3" Pintle Eye 20,000 lbs. (9,072 kg)	
#EE36264	
2" Ball Coupler 10,000 lbs. (4,536 kg)	
#EE43254	
2-5/16" Ball Coupler 14,000 lbs. (6,350 kg)	
#EE43253	

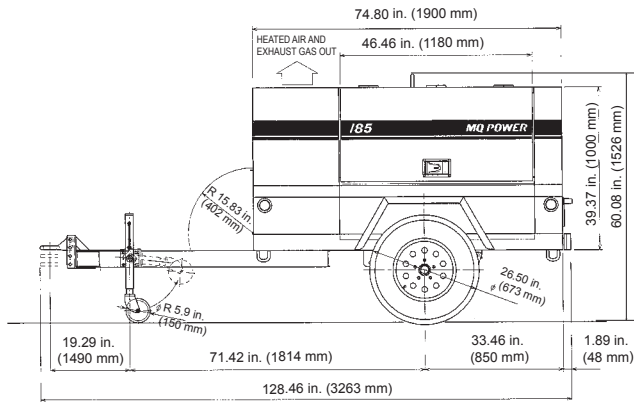
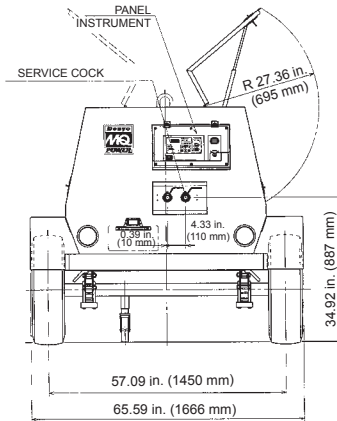
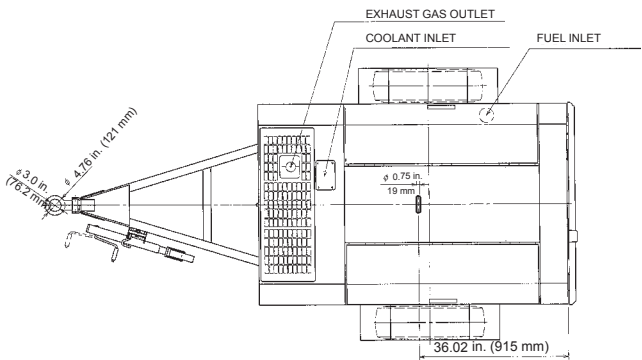

### WARRANTY\*

#### Isuzu Engine\*\*

12 months from date of purchase with unlimited hours or 60 months from date of purchase with 5000 hours (whichever comes first).

#### Air End

36 months from date of purchase or 3000 hours (whichever occurs first).

#### Air Compressor

12 months from date of purchase with unlimited hours.

\* Refer to express written, one-year limited warranty sheet for additional information.

\*\* Refer to Isuzu Diesel Engines Limited Warranty for details.

Manufactured by Denyo Co.

#### Your Multiquip dealer is:

Gonneville, Inc.  
 211 Calle Pintesresco Ste A San Clemente, CA. 92672  
 949-248-7297 | Sales@Gonneville.com



**MULTIQUIP**  
 POST OFFICE BOX 6254  
 CARSON, CA 90749  
 310-537-3700 • 800-883-2551  
 FAX: 310-604-3831  
 E-MAIL: sales@multiquip.com  
 WEBSITE: www.multiquip.com